

ELECTROMYOGRAPHIC STUDIES ON THE "NAGE-WAZA" (THROWING TECHNIQUES) OF JUDO

M. IKAI, T. ASAMI and M. KANEKO (University of Tokyo) T. SASA (Tokyo Medico-Dental University) Y. MATSUMOTO (Tokyo Univ. of Education)

Many new training apparatuses have been introduced into the Weight Training Center of the Kodokan, recently, and it is expected that training in muscle strength will very soon begin in real earnest. Accordingly, before planning a course in muscle strength training, the determination of what groups of muscles are used during performance of a technique is of utmost importance. Also, of great importance from the point of view of analysis of movement is the determination of the mode of change in space and in time of the contraction phase and relaxation phase of the muscles during performance of the various forms of "Nage-waza" (throwing technique). The cinematographic and the overlapping exposure methods have usually been employed in the analysis of movement. However, these visual methods are not sufficient as means of determining the mode of action of the muscles concerned. It is necessary to follow the locus of the movement, and to firmly grasp the mode of action of the various muscles of the body; and for these studies an electromyographical investigation becomes indispensable.

Before we go into further details of our experiment we shall first roughly describe the workings of the electromyograph (EMG). Electric current, although in very minute quantity, is produced when a muscle contracts. In order to detect this very minute quantity of electricity, a highly sensitive amplifier is necessary. There are two methods of picking up this electric current (action current), one is by the needle electrode, and the other is by the surface electrode. The former is directly thrust into the muscle and is used to lead action currents from individual nerve-muscle unit (consisting of motor nerve cell and nerve fiber, and the muscle fiber attached thereto); the latter is placed on the skin overlying the muscle, and is used to lead action currents in composite form. The needle electrode is used mainly in medicine as a diagnostic means (locomotor ataxia, myasthenia, cerebral diseases, infantile paralysis), and in physiology as a means of testing fatigue and reflex action, and also as a means of studying muscle action, however in this case it is limited to static activity. With the introduction of the pliable silver needle, recently, great improvements have been accomplished in the use of the needle electrode, however, due to the accompanying pain and also to the danger of the needle breaking, it is not used in the investigation of muscle activity during strenuous sports. Consequently, the surface electrode is preferable in electromyographical studies during active sports. The surface electrode is a silver disc about 10 mm. in diameter, and two of these are placed on the skin overlying the muscle

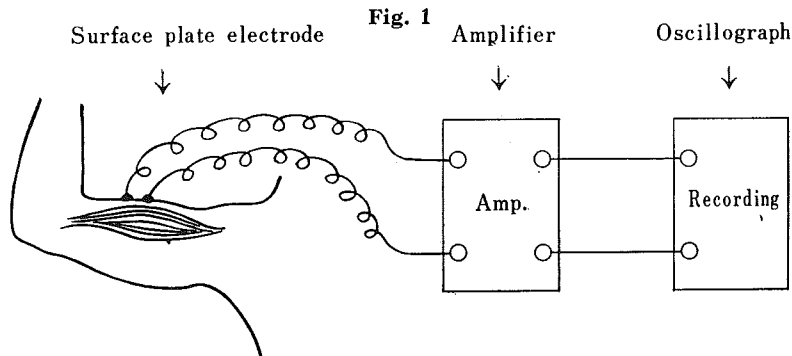

to be investigated (Fig. 1). Recently, the electromyograph has been extensively used in the field of sports science, and very interesting results of investigations such as "Electromyographical Studies of Swimming"¹⁾ and "Electromyographical Studies of Weight Lifting"²⁾ have been reported. Of special interest is the electromyographical studies made during swimming, as it was considered practically impossible to obtain leads during swimming. In Judo, Sato, last year (1961) reported on his "Electromyographical Studies on the Nage-waza of Judo" which is the only one of its kind so far.

We shall now explain what exactly may be learned from the electromyogram.

Our locomotor activity is centered around the mechanism of the skeletal system, and it is only possible with the close co-operation of the muscular and nervous systems. The muscle itself usually does not contract automatically, and it contracts only in response to nervous impulses sent through the motor nerves. Consequently, the electromyogram not only reveals the condition of muscular contraction, but also indirectly, the activity of the motor nerves. This motor nervous system is divided into the central and peripheral systems with the motor nerve cells (motor cells) of the spinal cord as the boundary between the two. Impulses from the cerebrum are transmitted to the motor cells which become excited and send through the nerve fibers which extends from here, repeated nerve action currents at short intervals, and produce action currents (spike discharges) in the muscles controlled by the nerve fibers. When the surface electrodes are being used these spike discharges appear as interference waves as shown in Fig. 2. By observing the frequency and amplitude of these waves, it is possible to deduce the degree of muscle contraction. In other words, from the height of the amplitude, and the frequency of the spikes it is possible to know the intensity of muscular activity. Regarding the relation of the amplitude and frequency of the discharges to muscle strength, T. Tokisane of University of Tokyo, Medical School, states that using surface electrodes, a linear increase in amplitude is seen up to a load of 20 kg., and above this load a fixed amplitude is maintained. Also, Sh. Nomura of the same University, Agricultural School, reports that an interrelationship exists between the recorded electric potential of the electromyogram and muscle strength,

Fig. 2 Electromyogram in muscular activity

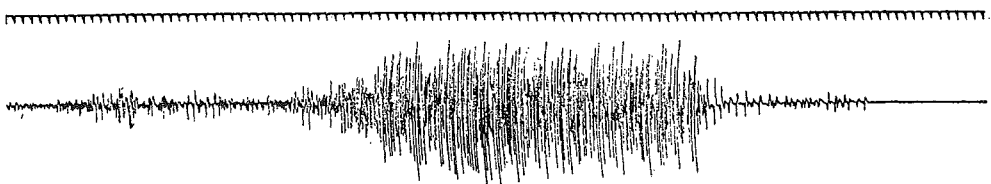

although the relation is not linear but stepwise. We have also investigated this problem by measuring the grip strength of Judoists and compared this to the average amplitude of the *m. flexor carpi radialis* and *m. extensor carpi radialis*, and found that the amplitude distinctly increased with the increase in muscle strength.

EXPERIMENTAL SUBJECTS.

Ten Judoists, all candidates for the coming Olympic Games, including Takeuchi, the winner of the 1961 All Japan Championship Tournament were selected as experimental subjects. Electromyograms were taken while each of these Judoists were performing their favorite techniques.

The following are the names of the Judoists and their favorite techniques:

Z. Takeuchi (V Dan), right Osoto-gari, left Tsurikomi-goshi, left Hane-goshi, left Osoto-gari, right Ko-uchi-gari, right Ko-soto-gari.

A. Tanaka (V Dan), right Hane-goshi, right Osoto-gari, right Harai-goshi, right Ko-uchi-gari.

K. Seki (IV Dan), left Tsurikomi-goshi, left Tai-otoshi, left Osoto-gari, left Ouchi-gari.

O. Nakaya (III Dan), left Kosoto-gari, left Osoto-gari, left Ouchi-gari, left Osoto-gaeshi.

S. Yoshigaki (IV Dan), right Seoi-nage, right Tsurikomi-goshi, right Harai-tsurikomi-ashi, left Tai-otoshi.

M. Hiraishi (IV Dan), right Osoto-gari, right Ouchi-gari, right Kouchi-gari.

J. Shirasaki (IV Dan) right Osoto-gari, right Ouchi-gari, left Harai-tsurikomi-ashi, left Harai-goshi.

Y. Maeda (IV Dan) left Osoto-gari, left Ouchi-gari, left Uchi-mata.

S. Sakaguchi (III Dan) right Osoto-gari, right Uchi-mata, right Harai-goshi, right Kouchi-gari, right Ouchi-gari.

The myographical studies were made at the Institute of Physical Education, Tokyo University, from June to August, 1962.

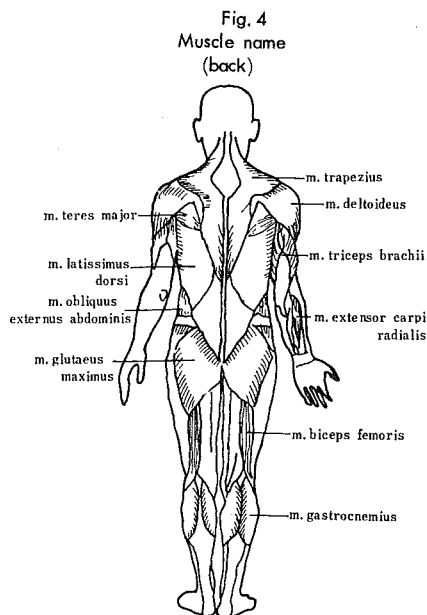
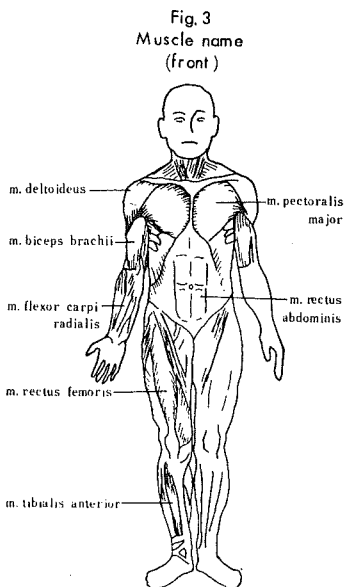

METHOD OF EXPERIMENT

Studies were made on the following 15 pairs of muscles (Figs. 3 and 4).

Upper extremity: m. flexor carpi radialis, m. extensor carpi radialis, m. biceps brachii, m. triceps brachii, and m. deltoideus.

Trunk: m. pectoralis major, m. rectus abdominis, m. trapezius, m. teres major, and m. latissimus dorsi.

Lower extremity: m. gluteus maximus, m. rectus femoris, m. biceps femoris, m. tibialis anterior, and m. gastrocnemius.

Two silver circular plate electrodes 10 mm. in diameter were placed on the skin overlying the muscles to be investigated. They were placed 3 cm. apart and in line with the direction of the muscle fibers. Recordings were made by a twelve element multi-electric recording apparatus capable of 100,000 times amplification, manufactured by the Sanei-sokki Instrument Co.. The experimental subjects were told to perform the techniques in a way so that they resembled as much as possible the actual performance during a tournament.

RESULTS AND DISCUSSION

The state of muscle activity during performance of a representative technique of each subject will be shown diagrammatically, and discussion will be made thereof.

Right Osoto-gari. Fig. 5 represents diagrammatically the electromyogram of Hiraishi. It demonstrates that during the "Kuzushi" (disturbing balance) strong discharges occur in the right m. trapezius. During the "Kake" (attack) strong discharges occur in the left m. biceps brachii, right m. deltoideus, right m. trapezius, and left m. rectus femoris. The left m. biceps brachii together with the m. flexor and extensor carpi radialis help further disturb the balance of the opponent. The right m. trapezius and the right m. deltoideus go into action in order to lift the opponent. The marked discharge from the left m. rectus femoris at this moment is due to the fact that the performer put his entire weight on his left toes. As the performance proceeded from the "Kake" to the "Nage" (throwing) the m. triceps brachii, m. teres major, m. latissimus dorsi, and m. biceps femoris took over the leading role. After a lapse of some moments, the activities of the left m. flexor and extensor carpi radialis, left m. biceps brachii, and left m. pectoralis major became evident. This is due to the performer supporting the opponent with his left hand.

Right Ippon-seoi. The Ippon-seoi of Inokuma is unique (Fig. 6). First, he disturbs the balance of his opponent to the front with only his left hand; and in this action the muscles which take the leading role are the left m. biceps brachii, and left m. deltoideus (see accompanying Photo). Next in order to fix the opponent's right arm, his m. biceps brachii, right m. deltoideus, and right m. trapezius take action. Simultaneously with this action, in order to fix the opponent's right arm with his left hand, his left m. triceps brachii and left m. teres major also go into action (see accompanying Photo). During the "Nage" the m. triceps brachii, m. teres major, and m. latissimus dorsi take the main role.

Yoshinaga's "Seoi-nage" is the so-called "Morote-seoi" (i.e. "Seoi-nage" using both hands) and does not use the muscle group of his left hand as much as Inokuma in order to unbalance

Fig. 5 Osoto-gari (right) sub: Hiraishi (IV Dan)

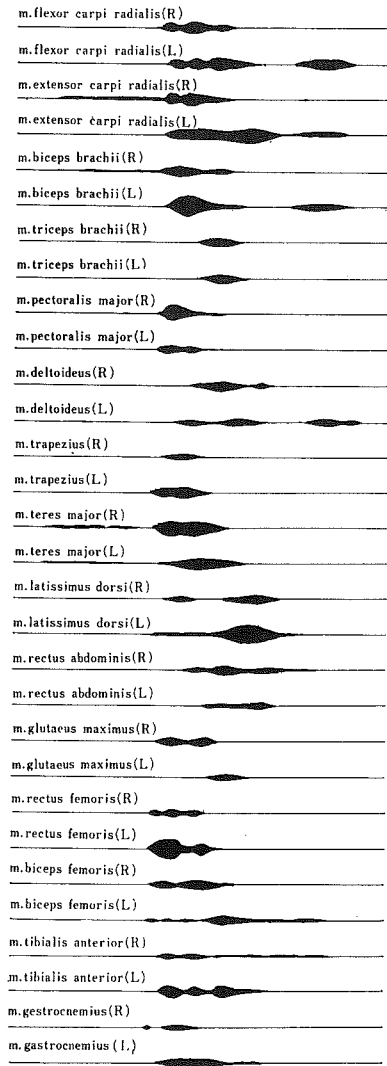

1 sec 2 mv



Fig. 6 Ippon-seoi (right) sub: Inokuma (VDan)

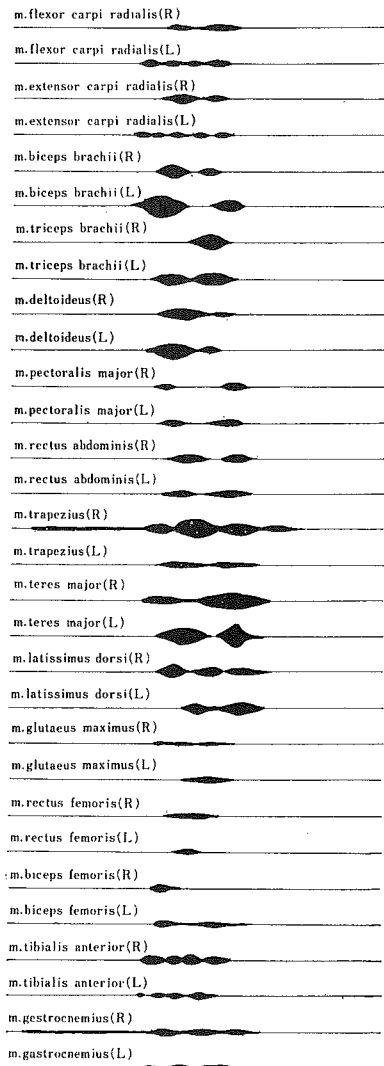

1 sec 2 mv

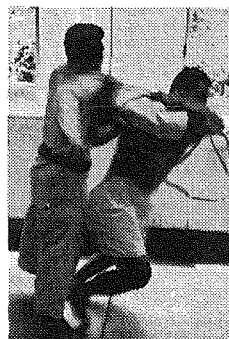

Fig. 7

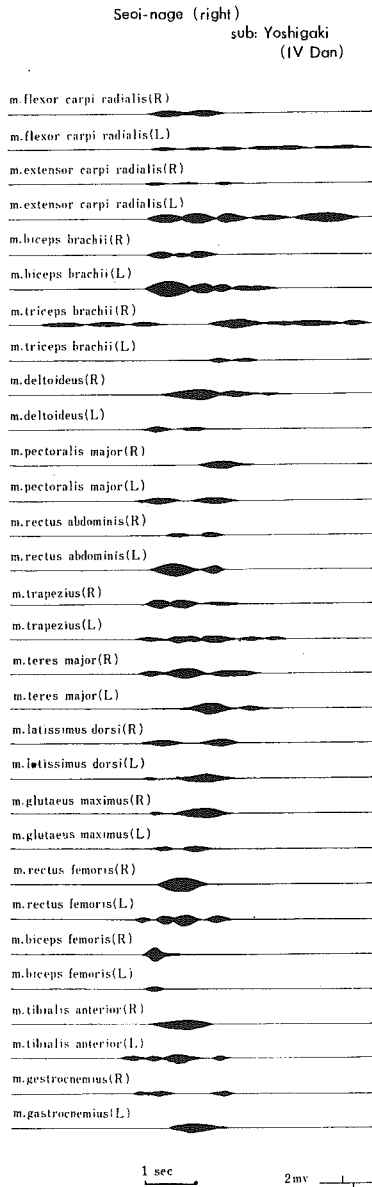

Fig. 8

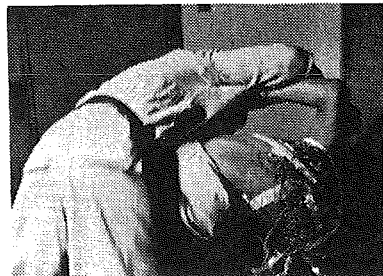
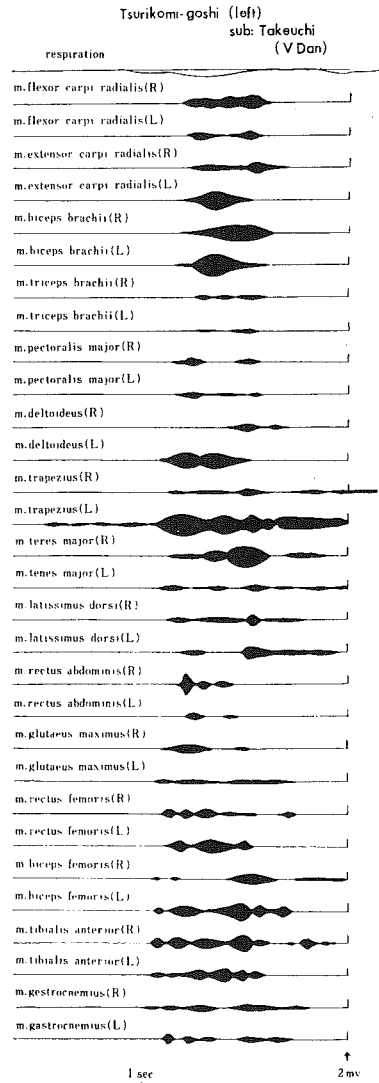

Fig. 9

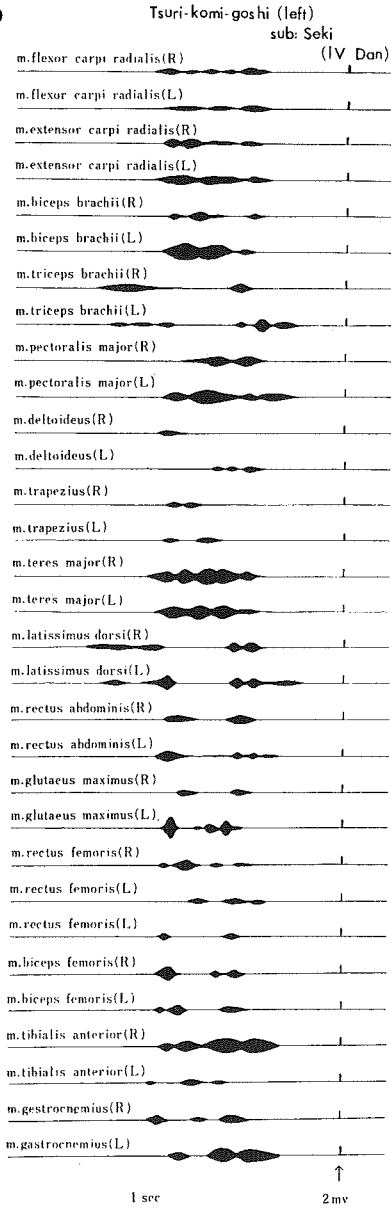

Fig. 10

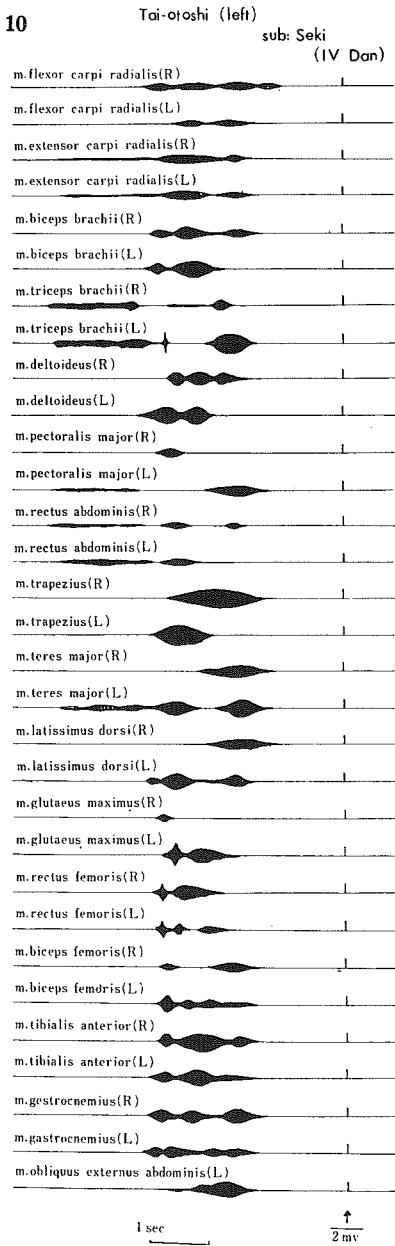

Fig. 11

Hane-goshi (right)
sub: Tanaka
(V Dan)

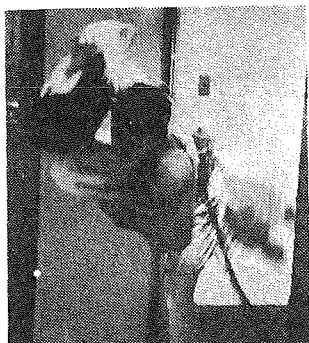
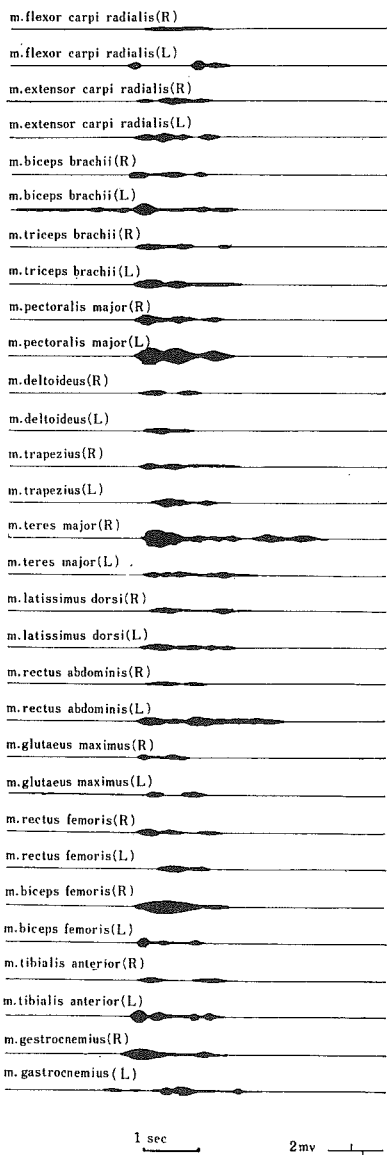
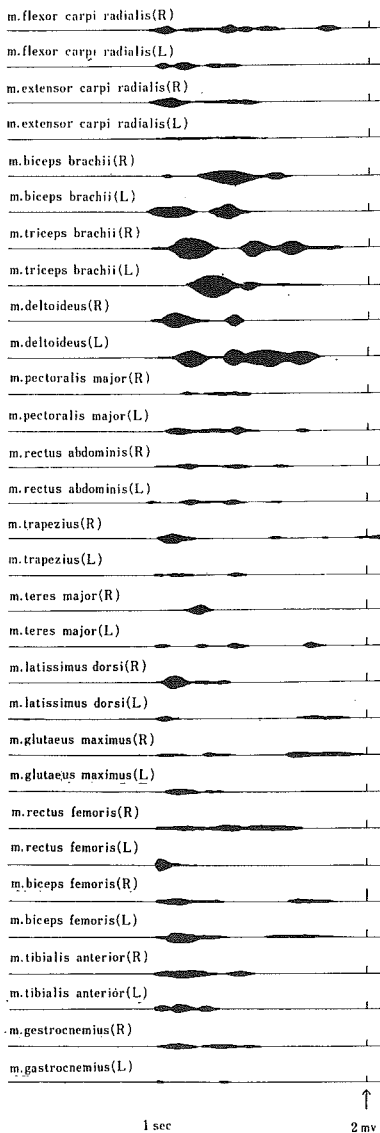

Fig. 12

Ouchi-gari (right)
sub: Shirasaki
(IV Dan)



his opponent (Fig. 7). However, during the "Kake", in order to draw in his opponent firmly, his m. extensor carpi radialis, and m. biceps brachii contract powerfully (see accompanying Photo). Also, in order to lift his opponent, his m. rectus femoris contracts very powerfully.

Left Tsurikomi-goshi. In both Takeuchi and Seki, the muscle groups on the left side of the body show marked activity; especially, in order to draw in the opponent, the left m. biceps brachii, left m. deltoideus, and left m. trapezius contract powerfully (Fig. 8). The distinctive feature of Takeuchi's Tsurikomigoshi is that his left hand plays the main role, and this may be recognized by the intense discharge seen in the EMG; especially marked are the discharges from the left m. trapezius. In the case of Seki (Fig. 9) the m. triceps brachii and m. teres major go into action during the "Kuzushi", as seen from the strong discharges seen therefrom, however, when he goes into the "Kake" the discharges from these muscles disappear, and are replaced by strong discharges from the left m. biceps brachii, left m. deltoideus, left m. trapezius, and left m. gluteus maximus.

Left Tai-otoshi. In Seki's Tai-otoshi (Fig. 10) like in his left Tsurikomi-goshi, the back muscles (m. extensor carpi radialis, m. triceps brachii, and m. teres major) go into action during the "Kuzushi", and when he goes into "Kake", discharges from the m. triceps brachii disappear and are replaced by strong discharges from the left m. biceps brachii, left m. deltoideus, and left m. trapezius. During the "Nage" the back muscles again go into action. As the technique is performed in two separate steps, two separate groups of discharges are seen from the leg muscles; especially marked are discharges from the right m. rectus femoris, and right m. tibialis anterior. The characteristic feature of Seki's EMG is that the contraction phase and the relaxation phase are very distinct, which is very important from the point of view of nervous control.

Right Hane-goshi. Tanaka's Hane-goshi is very similar to the right Tobi-komi-uchimata, the only difference being that in one the leg which sweeps up the opponent is applied to the opponent's right leg whilst in the other it is applied to his middle. From the "Kuzushi" to the "Kake" the left m. biceps brachii, and the left m. deltoideus contract very powerfully, although only for a moment. In the right arm the right m. trapezius take the main role of action in order to lift the opponent. When the performer sweeps up his opponent, he lifts his leg in extension, and consequently, marked discharges are seen in the EMG of the m. biceps femoris, and the right m. gastrocnemius.

Right Ouchi-gari. In Shirasaki's right Ouchi-gari, the right hand is used to push the opponent's shoulder in order to disturb the opponent's balance to the left rear corner, and consequently, the extensor muscles (right m. extensor carpi radialis, and right m. triceps brachii) act powerfully. Simultaneously with this, marked discharges from the left m. biceps brachii and the left m. deltoideus may be observed. This is due to the fact that the left arm helps the right arm in unbalancing the opponent. The marked discharges from the left m. triceps brachii and the left m. deltoideus indicate that the "Kuzushi" to the rear is taking effect (Fig. 12).

SUMMARY

1) From the "Kuzushi" to the "Tsukuri" and the "Kake" the muscles in the frontal aspect of the body do most of the work, whereas during the "Nage", the back muscles go into action and contract powerfully.

2) In the Judoists who are right sided in their techniques, the action of the muscles on the left side of their bodies is important, whereas during the "Kake" the contraction of the muscles on the right side of his body take over the main role.

3) Antagonistic action of the muscle groups of the forearm was not very evident, however, a marked antagonistic action between the m. biceps brachii and the m. triceps brachii was noted. It is important that muscle groups not concerned with the movement be relaxed, and those concerned with the motion be contracted.

4) When the contraction phase and the relaxation phase of muscle activity are very distinct, it means that the nerves controlling the muscles are functioning adequately.

5) In the "Uchi-mata", "Hane-goshi", and "Harai-goshi" in which the performer disturbs the opponent's balance to the front and attacks with one of his legs, the m. biceps brachii, m. deltoideus, and m. trapezius take over the main role of action.

6) And in the "Tsuru-komi-goshi", "Seoi-nage", and "Tai-otoshi" in which the performer uses both legs in his attack, the m. teres major goes into action, besides these three muscles.

7) In the "Ouchi-gari", and "Kouchi-gari" in which the performer attacks after disturbing the balance of his opponent to the rear, the m. triceps brachii, and m. deltoideus take over the main role of action while the m. extensor carpi radialis, m. biceps brachii, and m. trapezius act in an auxiliary manner.

From the foregoing it will be understood that in Judo, the m. biceps brachii, m. triceps brachii, m. deltoideus, m. trapezius, m. teres major, and m. rectus femoris take the main role of action. However, depending on the kind of "Nage-waza" the manner of action of the muscles differ, and consequently, training should be performed in a way to match the favorite technique of each Judoist.

Reference

- 1) Ikai, M., Ishii, K. and Miyashita, M.: Electromyographic Study of Swimming. OLIMPIA. No. 8, 258-263. 1961.
- 2) Nomura, S., Ono, M., and Kubota, N.: Electromyographic studies of weight lifting. Jap. Asso. of sports. 1961.